

# labmodul

Designing safety

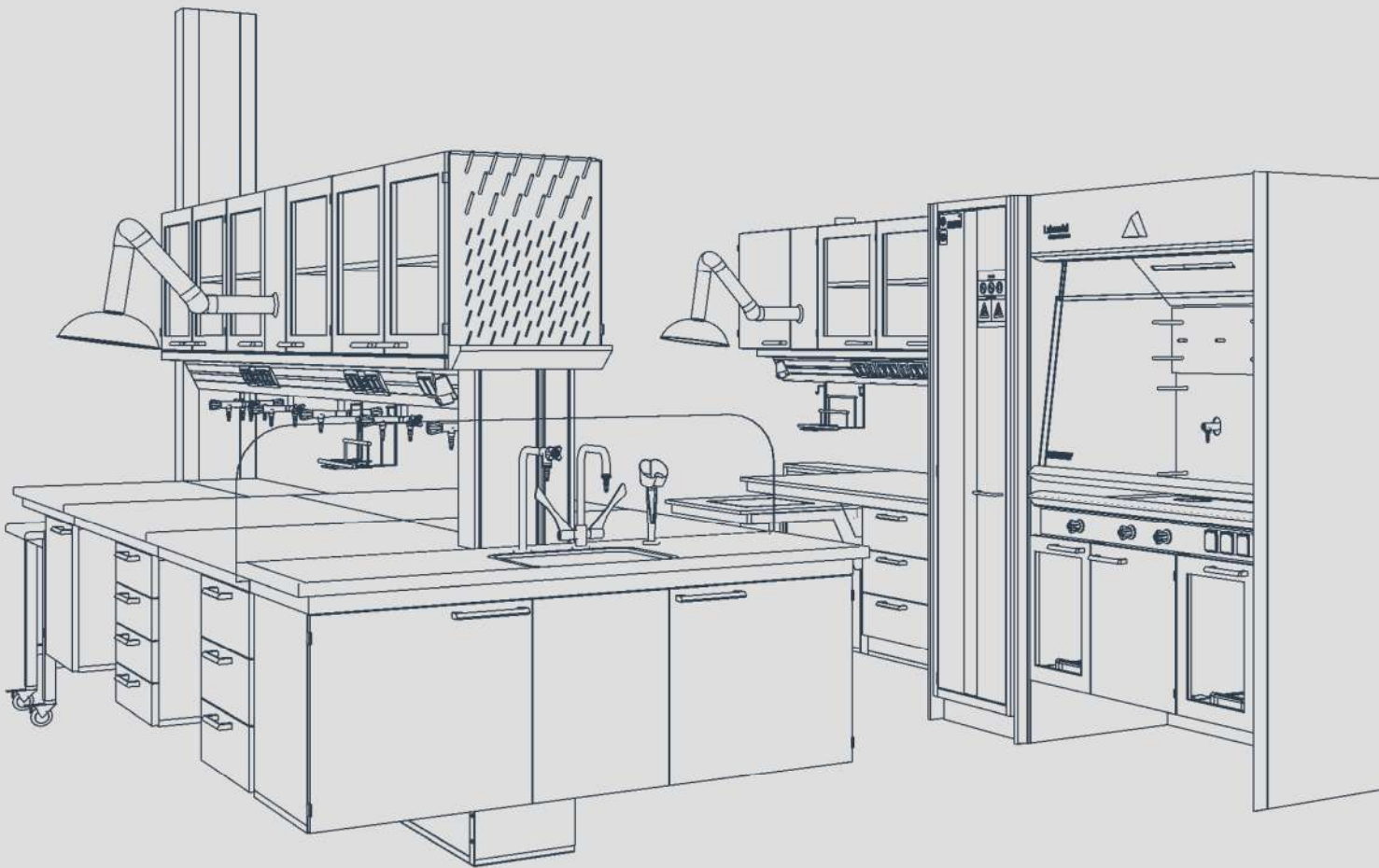

# Designing safety...



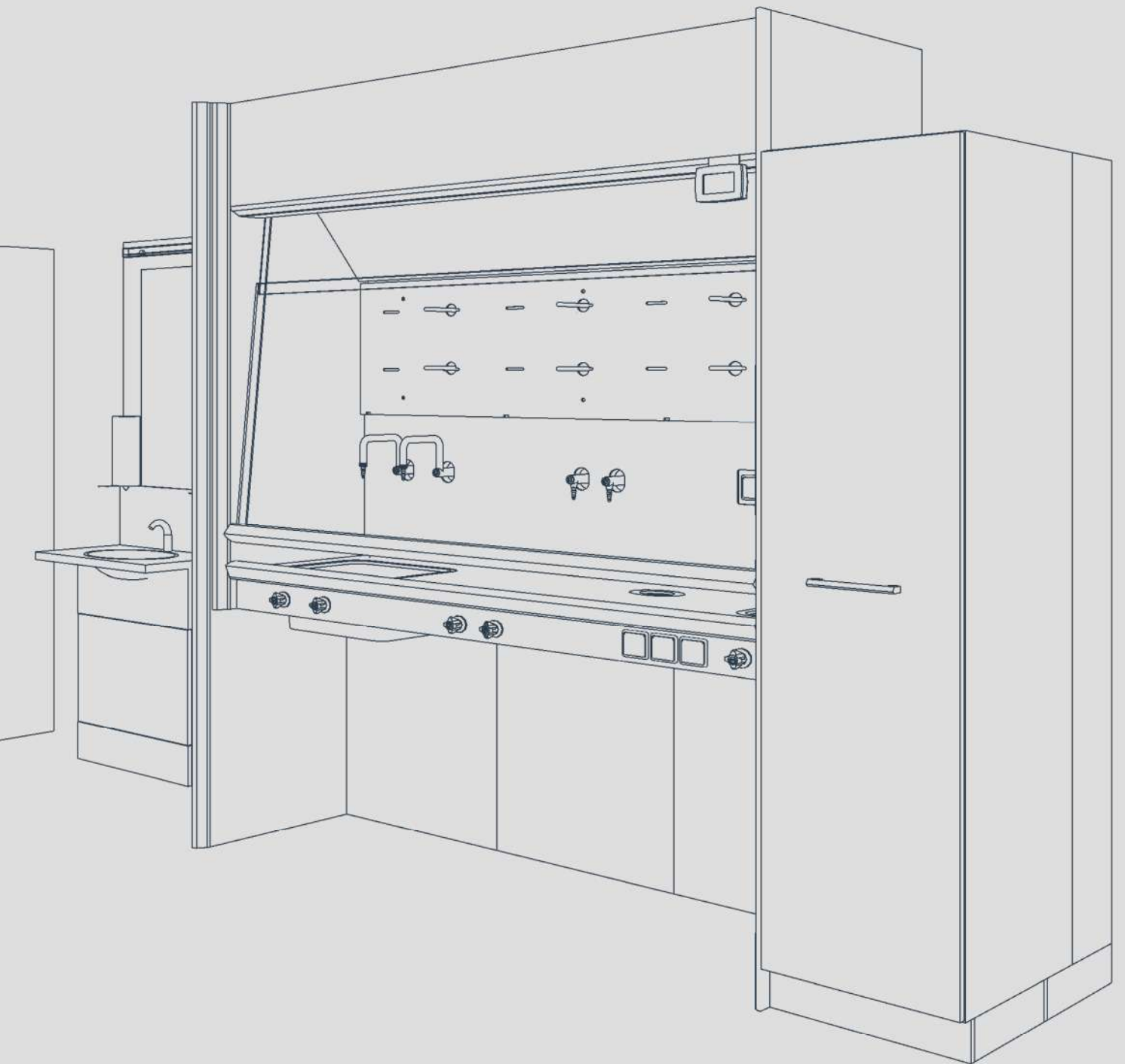







labmodul



SYSTEM PERFORMANCE

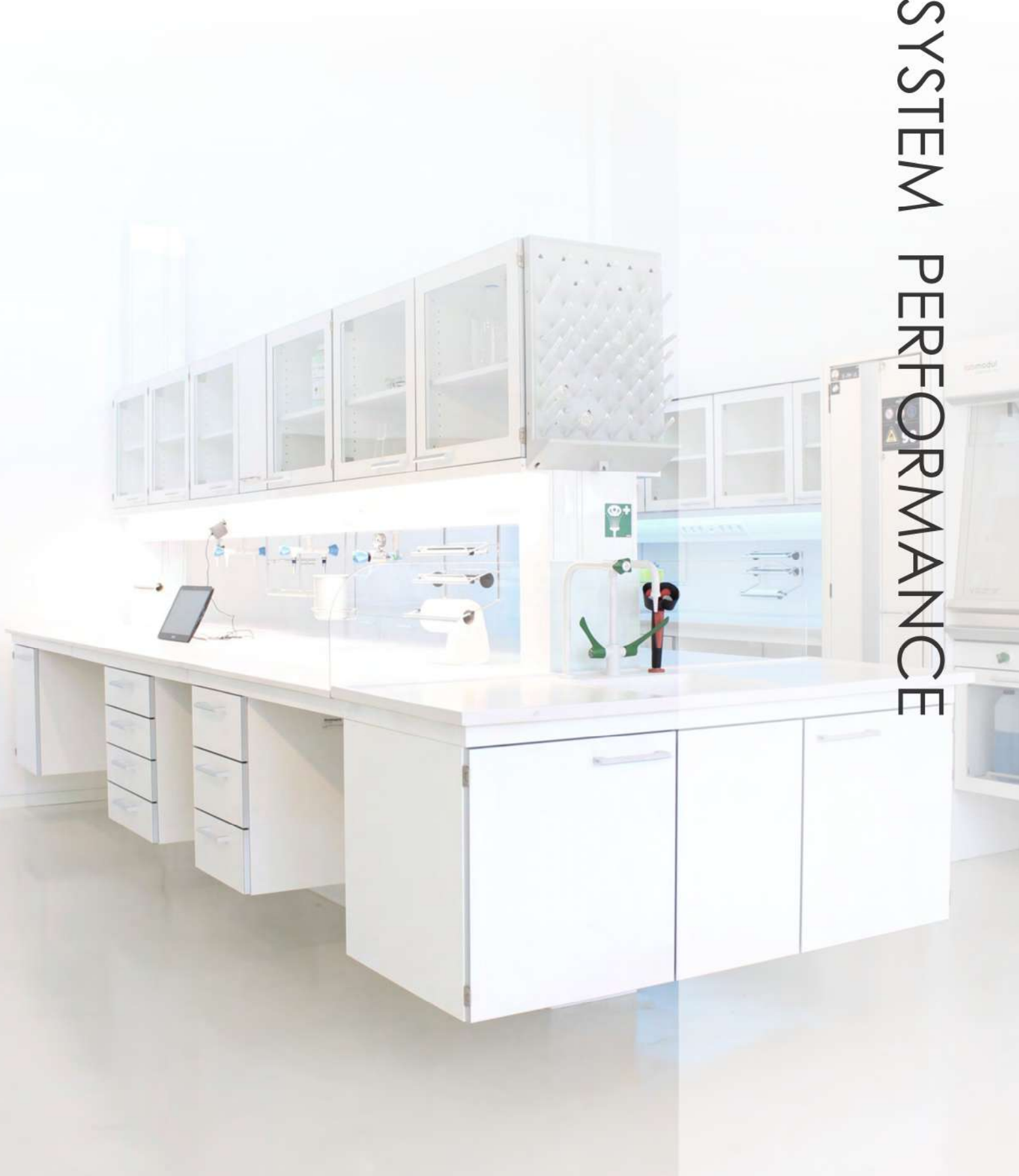

# SYSTEM PERFORMANCE

- Flexible and interchangeable
- Future-proofed and suited for all purposes
- High quality for daily use
- Designed for GMO facilities
- Smart design
- Ergonomically adjustable
- Easy to clean



## System Performance

PERFORMANCE is a furniture system with no supporting legs, designed to provide the highest degree of flexibility as well as cover future demands. The system is compatible with our other system solutions.

All constructions are thoroughly tested and the furniture system is made of resistant and robust materials to offer a durable solution suitable for many years of daily use.

Furthermore, the materials are carefully chosen with regard to recycling and sustainability.

The performance furniture system secures an exceedingly easy cleaning friendly laboratory that meets all regulative requirements for cleanrooms and GMO classifications





## A wide selection

Performance offers a wide range of different worktop and front materials to choose from along with different types of hinges and drawer handles to fit the desired cabinet function precisely.

Drawers are delivered with 80 % soft close pull-out as standard or with 110 % soft close pull-out.

The base cabinets are mounted hanging in runners and can easily be moved by pulling the cabinet sideways

The flexibility allows for the establishment of sitting and working places as well as situating equipment beneath the worktop exactly where you need it.

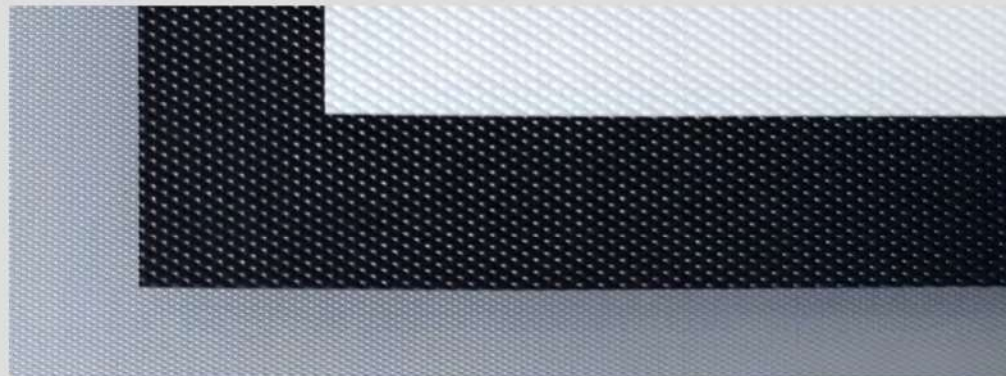





## Excellent ergonomics

The modular sections provide a continuous and ergonomically correct adjustment of the worktops for each user or task. The sections can further be removed, in case of a future need for extra space or for larger equipment and devices.

The tabletops are offered with height adjustability.

The height-adjustable systems come in 2 versions:

- ◆ Hidden actuators with a height adjustment of 75 to 91 cm
- ◆ Visible actuators with a height adjustment of 70 to 110 cm

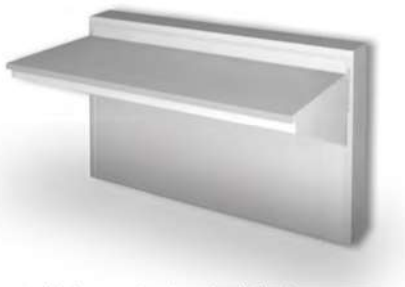

Hidden actuators built in the panel module. Carries 120 kg



Visible actuators built in the panel module. Carries 130 kg



Wall module with visible actuators. Carries 125 kg









System Performance Technical Drawings

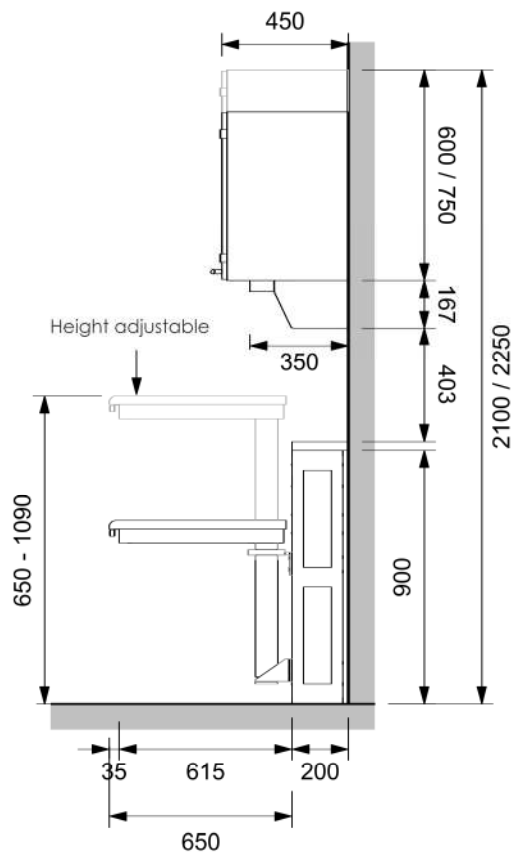
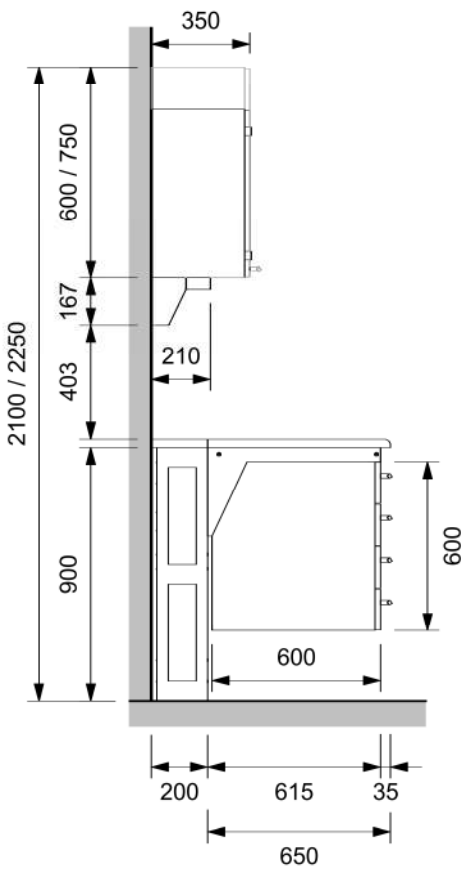
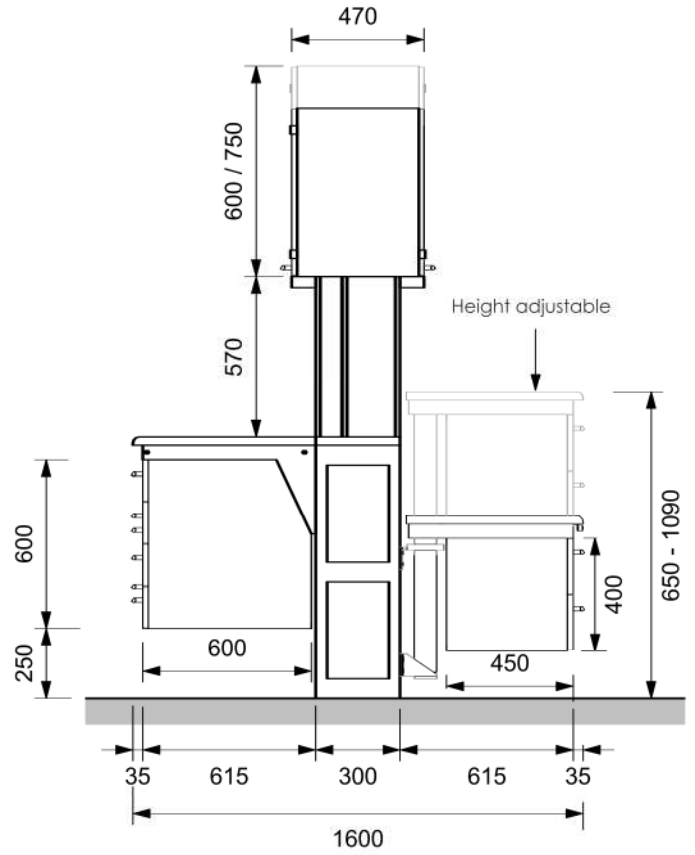
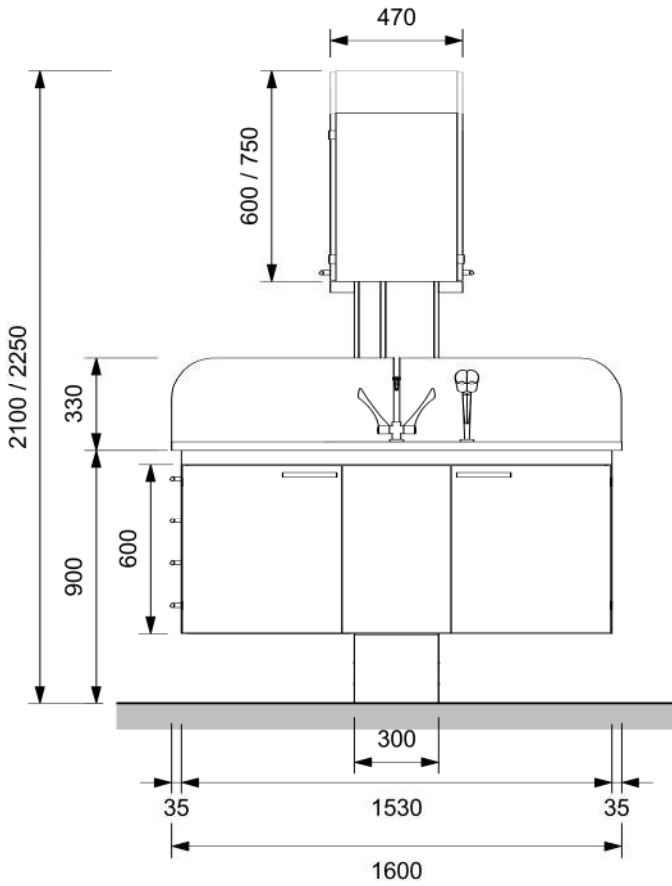

## System Performance - Installations

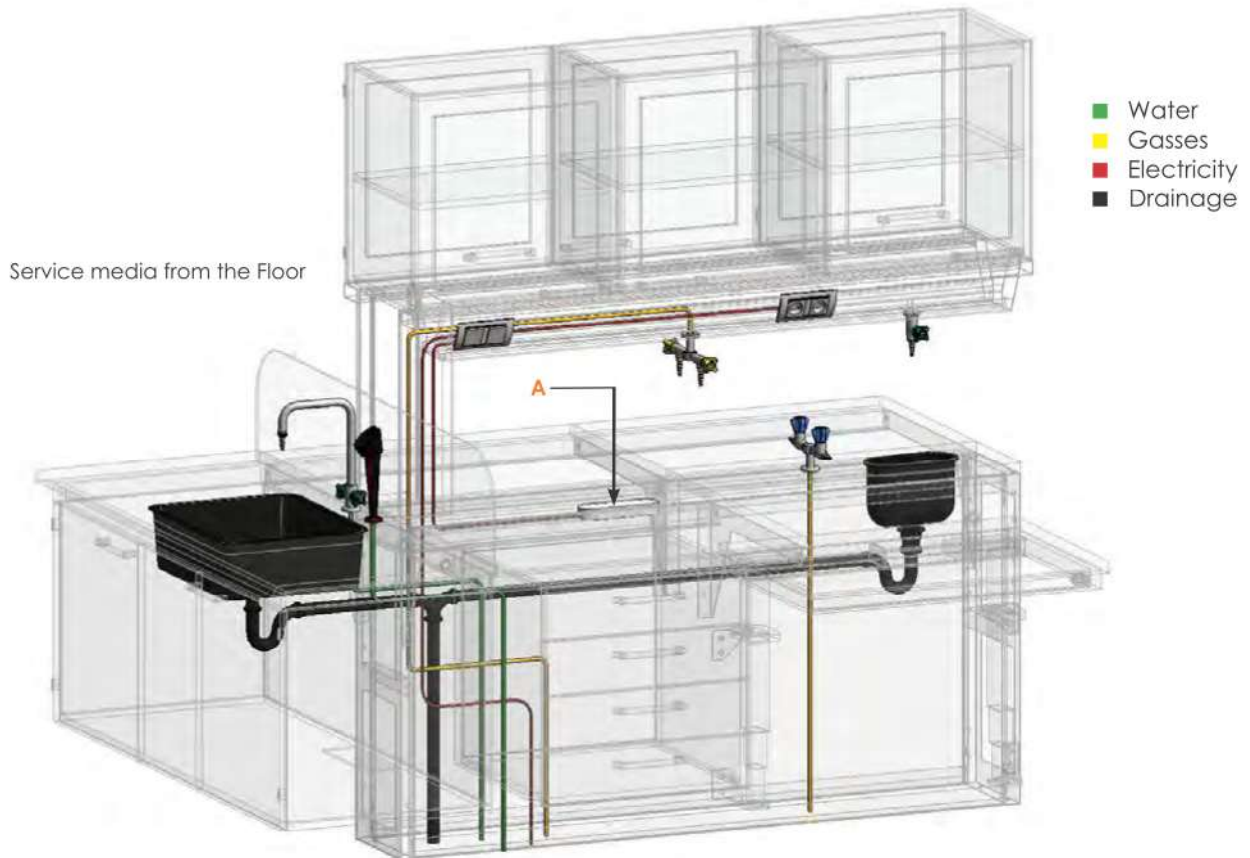

- A Sockets that come with the service bridge when we deliver height-adjustable support frames to the Performance system

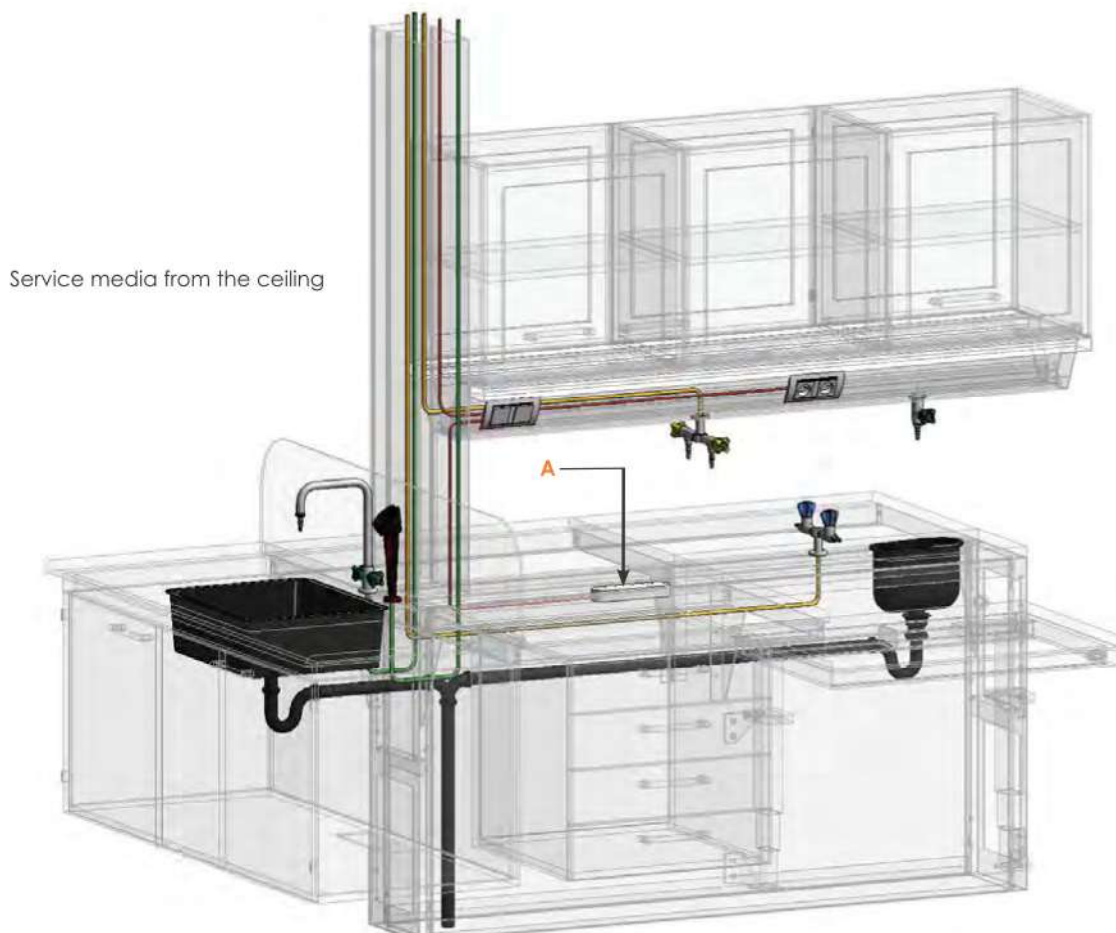











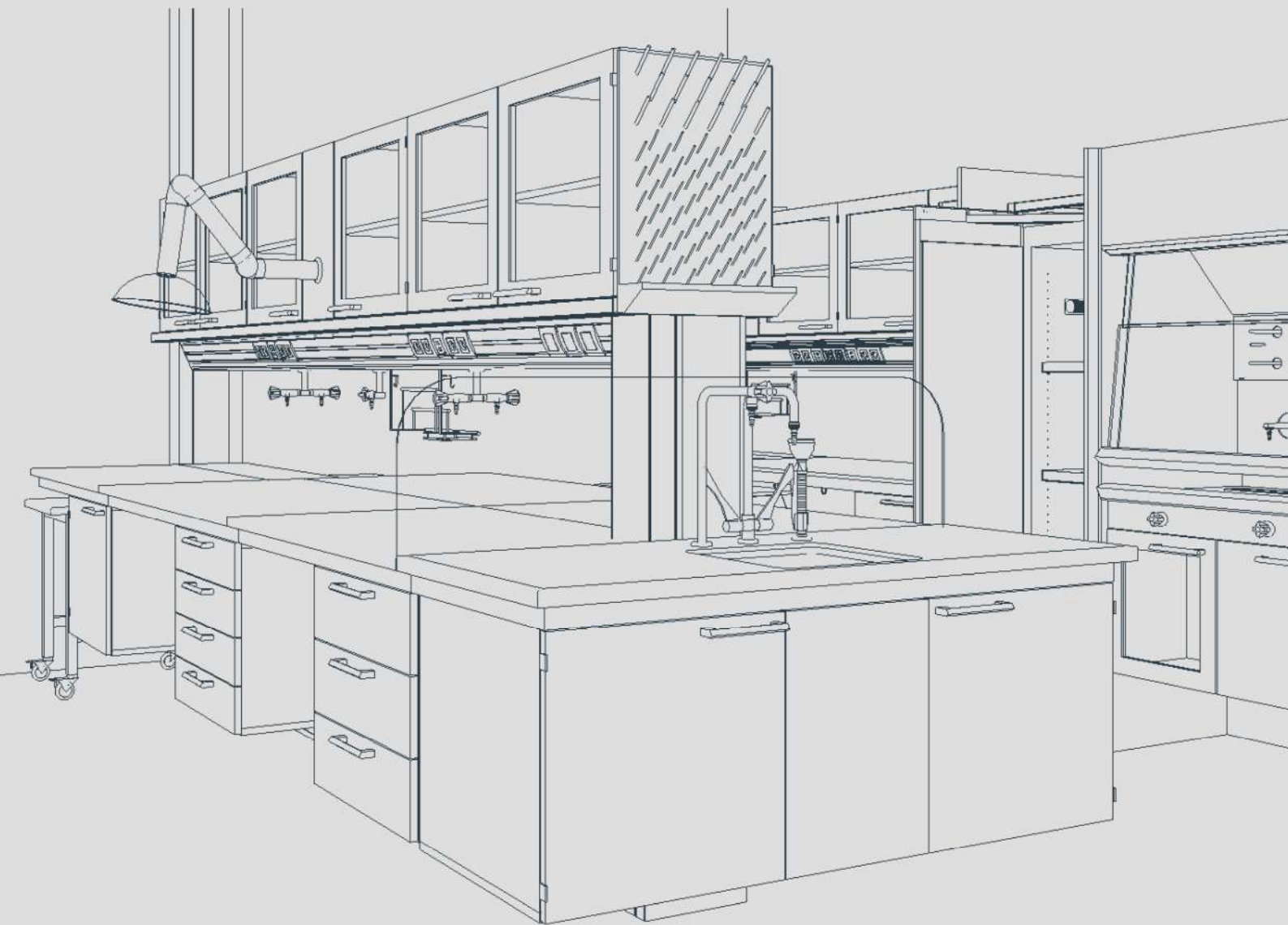







**labmodul**  
Designing safety

Version: ★ ★ ★

LABMODUL A/S

Valhøjs alle 190  
DK-2610 Rødovre  
info@labmodul.dk